

# RCU

RADIO CONTROL UNIT

RCU-5056

STACKABLE VERSION SERIAL/ITEM 533/nnn

---

## OPERATOR HANDBOOK

Version 1.2 - MARCH, 2006

---

DESIGNED AND MANUFACTURED IN AUSTRALIA

**design2000**

**DESIGN TWO THOUSAND PTY LTD**

ACMA SUPPLIER'S CODE NUMBER N468

---

DESIGN TWO THOUSAND IS CERTIFIED TO ISO9001

MADE IN AUSTRALIA

---

# DOCUMENT CONTROL

<b>Document Number</b>	G/06165
<b>Document Name</b>	Radio Control Unit RCU-5056 Handbook
<b>Security</b>	Commercial In Confidence
<b>Circulation</b>	Fujitsu
<b>Prepared By</b>	Peter Zeug
<b>Reviewed By</b>	Ross Kells, Srijuth Wimalajeewa (UD)
<b>Approved By</b>	

Version Control	Edition	Date	Notes
	Draft 1	24/02/2006	First Draft
	Draft 2	27/02/2006	Grammar corrections
	1.0	01/03/2006	DTMF Test tones now A & D.
	1.1	02/03/2006	UD's review comments addressed
	1.2	16/03/2006	Status messages defined Sequence diagrams included



# RADIO CONTROL UNIT RCU-5056

## USER HANDBOOK

SECTION	CONTENTS	PAGE
1	<b>Service Information</b>	1
2	<b>Introduction</b>	2
2.1	Overview	2
2.2	Description	2
2.3	RCU Features Summary	3
3	<b>RCU Controls, Indicators &amp; Connectors</b>	4
3.1	RCU Controls	4
3.2	RCU Front Panel LEDs	4
3.3	RCU Connectors	5
4	<b>Installation</b>	6
4.1	Connection Diagrams	7
4.2	Radio Control Port	8
4.3	Power	9
4.4	Diagnostic RS-232 Port	10
4.5	USB Connection	10
5	<b>Cable Assembly Diagrams</b>	11
6	<b>Functional Description</b>	12
6.1	Control Channel Test	12
6.2	Traffic Channel Test	12
6.3	Mode Change	13
7	<b>RCU Interface Specification</b>	14
7.1	RCU Sequence Diagrams	14
8	<b>RCU Firmware</b>	17
9	<b>Specifications</b>	18
	Packing List	20
	Self-Test Mode	21

N468



DESIGNED AND MADE IN AUSTRALIA

**design2000**

DESIGN TWO THOUSAND PTY LTD

FOR

**FUJITSU**

OSS Technologies

© Copyright 2006

---

## **1. SERVICE INFORMATION**

If problems are experienced with the installation or operation of the Radio Control Unit please call the Help Desk Number listed below before returning units to the factory for repair.

In many cases, problems can be diagnosed and rectified over the phone, avoiding unnecessary transportation and service costs.



**HELP DESK NUMBER:**

+61 3 9758 5933 (All hours)

---

# RADIO CONTROL UNIT RCU-5056

## 2. INTRODUCTION

The Radio Control Unit (RCU) is a custom hardware development for the State Mobile Radio Network Service Performance Monitoring (SMR-SPM) project. It connects to a Simoco SRM9000 Radio Transceiver allowing it to operate as a Test Transmitter Receiver (TTR) when in the Trunked mode of operation.

### 2.1 OVERVIEW

The RCU's logical representation is shown in Figure 1.

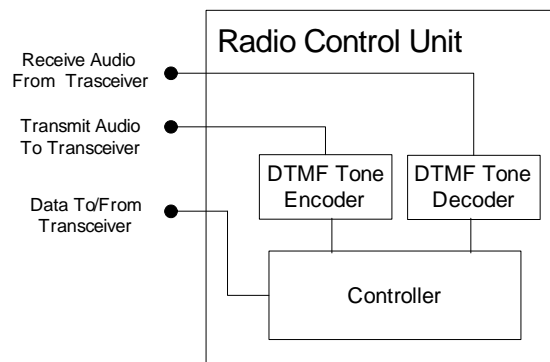

Figure 1: RCU Logical Representation

The RCU functions include:

- Respond to Trunk Traffic Channel Tests initiated by the RTR-T
- Change the mode of the Radio Transceiver from Trunked to PMR mode for a specified time when instructed by the RTR-T
- Change the mode of the Radio Transceiver from PMR to Trunked mode when the specified time expires.

### 2.2 DESCRIPTION

When a Trunk Channel test is to be performed, the RCU will detect an incoming call and answer. It will then wait for a series of DTMF test tones to be sent by the RTR-T which it detects using its DTMF decoder. If the DTMF tones are the expected test tones, it will respond with DTMF acknowledgement tones using the DTMF encoder and wait for the RTR-T to terminate the call.

The RCU is connected to a dual mode Transceiver. As the Transceiver must perform TTR functions when in both Trunked and PMR modes of operation, the mode of the Transceiver can be switched by a remotely initiated command. This is performed by sending a control message containing "Mode Change" details from the RTR-T. When the control message is detected by the RCU containing a request to change from Trunked to PMR mode and the period for which it is to remain in PMR mode, the RCU responds to the RTR-T and changes the mode of the transceiver to PMR for the specified period of time.

---

Once the mode of the transceiver is in the PMR mode of operation, the RTR-T is unable to communicate to the RCU. The RCU will keep the transceiver in the PMR mode of operation until the time period specified in the “Mode Change” control message sent previously expires - after which the RCU changes the mode of the transceiver back to the Trunked (default) mode of operation.

### 2.3 RCU FEATURES

<b>FEATURE</b>	<b>RCU-5056</b>
Single Enclosure Design (no external boxes)	✓
12V dc Working	✓
dc Supply Indicator	✓
MAP27 Interface	✓
Diagnostic RS232 Interface	✓
DTMF Receiver	✓
DTMF Transmitter	✓
Control Channel Integrity Test	✓
Traffic Channel Integrity Test	✓
PMR Selcall Encode	✓
End to End Testing	✓
Firmware flash upgradeable via USB	✓

*Figure 2: Table of RCU Features*

---

### 3. RCU CONTROLS, INDICATORS & CONNECTORS

#### 3.1 RCU CONTROLS

The RCU has a Reset button and an Update button for performing firmware upgrades via the USB 2.0 Type B port. The function of these buttons is described in the 'Update Procedure' (separate document).

#### 3.2 RCU FRONT DISPLAY LEDs



Figure3: RCU Front View

Visual indication of operating progress is provided by five LEDs on the front panel marked POWER, ACTIVITY, TESTING, TRUNK, & PMR.

POWER	13.8Vdc nom. power is connected and the internal fuse is intact.
ACTIVITY	RCU has MAP27 link Activity with the TTR
TESTING	RCU is busy testing the Trunked or PMR network
TRUNK	RCU has the TTR in Trunked mode & can be testing the Trunked network
PMR	RCU has the TTR in PMR mode & can be testing the PMR network
ACTIVITY & TESTING	When these two LEDs alone are both blinking very rapidly, the 'UPDATE' button has been pressed for 3 seconds or more & the RCU is waiting for a firmware flash update via the USB UPGRADE port

---

### 3.3 RCU CONNECTORS



*Figure 4: RCU Rear View*

MAP27 Radio Control ( <u>front panel</u> )	RJ45
Diagnostic RS-232	RJ45
TTR Radio	DB15 Female
13.8Vdc nom. power input	DB15 Male



---

## **4. INSTALLATION**

The RCU has been specially designed to suit the Simoco SRM9000 TTR Radio. The TTR Radio may be screwed directly to the top of the RCU using 4 x M4 10mm screws. The RCU and the TTR Radio may also be placed side by side.

Installation is essentially 'plug and play' as described as described in the following pages.

---

## 4.1 CONNECTION DIAGRAMS



*Figure 5: RCU/TTR Rear View*

Interconnecting Cable DB15 male to DB15 female, Part Number CA-506410  
Simoco Power/Speaker Cable, BNC Antenna socket.

**Please Note:** Connecting a speaker to the GY/BK cable is optional  
COM 2 port is for diagnostic purposes only



*Figure 6: RCU/TTR Front View*

Interconnecting Cable RJ45 plug to RJ45 plug, Part Number CA-506411

---

## 4.2 CONNECTING THE RADIO CONTROL PORT

The RCU Radio Control Port on the front panel is connected to the Radio's Control Head port via the supplied RJ45-RJ45 lead. The Radio Control port RJ45 Pin assignments are:

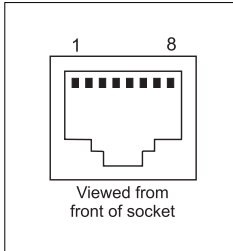

<b>PIN</b>	<b>ASSIGNMENT</b>
1	RxD (Data IN to RCU from Radio)
2	TxD (Data OUT from RCU to Radio)
3	NC (On/Off)
4	MIC Ground
5	NC (SW Out)
6	Audio IN to RCU from Radio Handset Audio out
7	Ground
8	Audio OUT from RCU to Radio MIC Audio in

### 4.3 CONNECTING THE POWER SUPPLY & POWER TO THE RADIO

The Simoco DB15 Power/Speaker cable supplied is connected to a nominal 13.8Vdc power source and to the DB15 ‘POWER’ connector (PL3) on the RCU. A pass-through connection is provided on the RCU to feed power to the Radio via DB15 connectors. The two are interconnected using the DB15-DB15 cable supplied. Pin assignments for the DB15 connectors are:

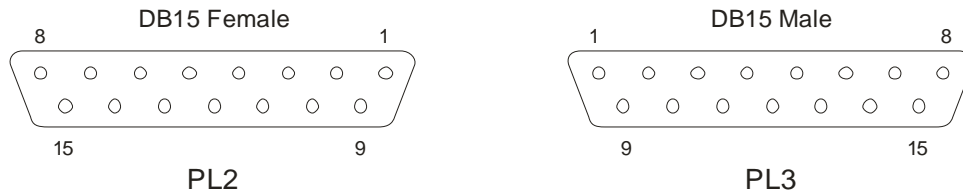

Note: PL2 & PL3 are as viewed from the face of the connector

DB15 FEMALE PL2 CCONNECTOR RADIO		DB15 MALE PL3 CONNECTOR POWER	
PIN	ASSIGNMENT	PIN	ASSIGNMENT
1	13.8Vdc nom. -ve	1	13.8Vdc nom. -ve
2	13.8Vdc nom. -ve	2	13.8Vdc nom. -ve
3	IGN Sesne (To LK1, NC)	3	NC
4	13.8Vdc nom. +ve	4	13.8Vdc nom. +ve
5	13.8Vdc nom. +ve	5	13.8Vdc nom. +ve
6	Speaker to PL3 PIN 6	6	Speaker from PL2 PIN 6
7	GP Output from RCU to Radio (eg. PTT)	7	NC
8	GP Input to RCU from Radio (eg. COS/CD)	8	NC
9	13.8Vdc nom. -ve	9	13.8Vdc nom. -ve
10	13.8Vdc nom. -ve	10	13.8Vdc nom. -ve
11	13.8Vdc nom. +ve	11	13.8Vdc nom. +ve
12	13.8Vdc nom. +ve	12	13.8Vdc nom. +ve
13	Speaker to PL3 PIN 13	13	Speaker from PL2 PIN 13
14	Audio OUT from RCU to Radio	14	NC
15	Audio IN to RCU from Radio	15	NC

**Please Note: For the RCU/TTR application, only the 13.8 Vdc power connections are used.  
Tx & Rx Audio is sent & received via the Radio Control Port on the front panel.**

---

## 4.4 CONNECTING THE DIAGNOSTIC RS-232 SERIAL PORT

The port is for diagnostics. The RJ45 Pin assignments are:

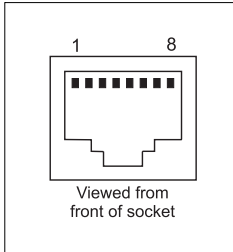

PIN	ASSIGNMENT
1	NC
2	NC
3	TxD (Data OUT from RCU)
4	NC (TxD2)
5	RxD (Data IN to RCU)
6	Ground
7	NC (KBI1)
8	NC (RxD2)

## 4.5 USB CONNECTION

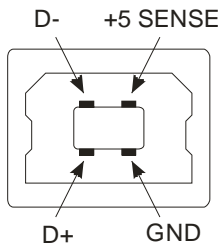

The RCU's firmware can be upgraded using a standard USB patch lead with a Type A male plug (PC) to a Type B male (RCU) plug.

---

## 5. CABLE ASSEMBLY DIAGRAMS

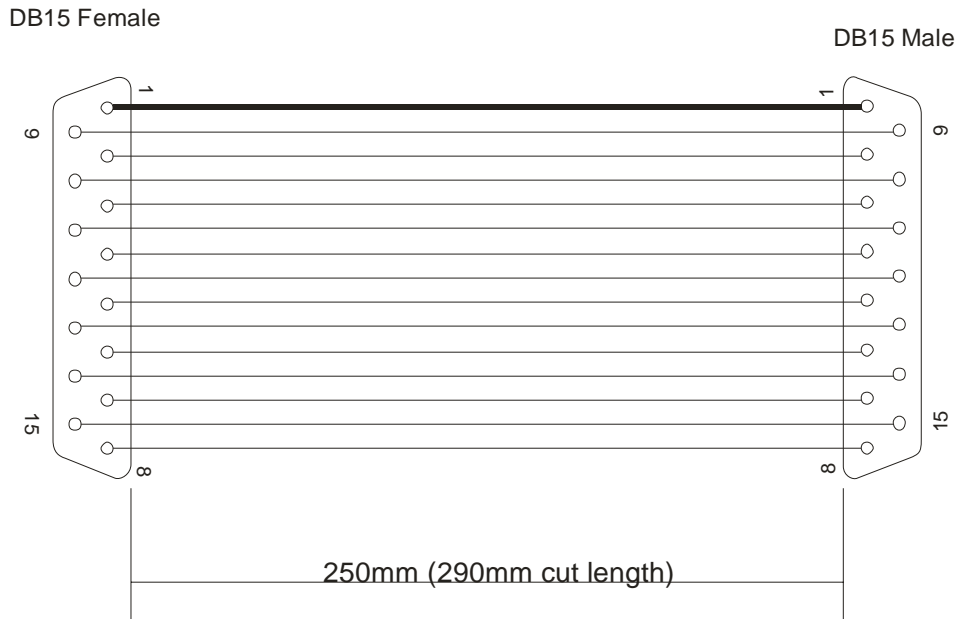

DB15 FEMALE TO MALE  
CA-5063 sht 10  
Viewed wiring side of connector

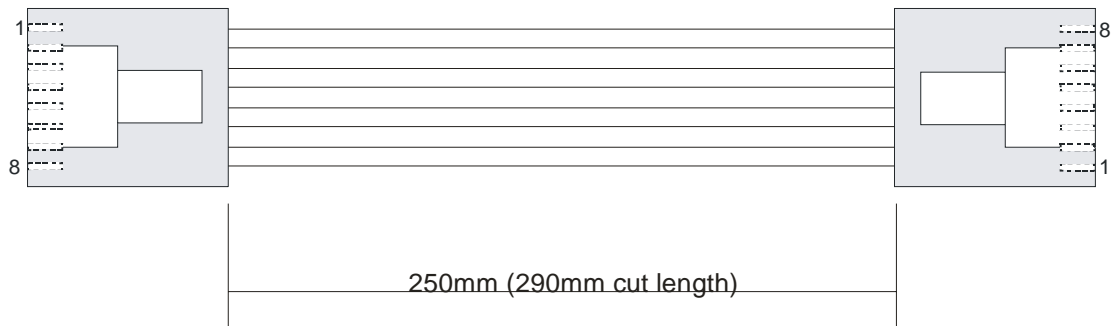

RJ45 to RJ45 (pins connect 1 to 8)  
CA-5063 sht 11

---

## **6. FUNCTIONAL DESCRIPTION**

As the RTR-T/P can only communicate with the RCU when the TTR is in the Trunked mode of operation, the RCU defaults the TTR to the Trunked mode of operation after a reset. The RCU interrogates the Radio Transceiver periodically to ensure that it is in the correct mode of operation.

### **6.1 CONTROL CHANNEL TEST**

- T&D issues a command for the RTR-T to perform a Trunk Control Channel Test.
- T&D specifies the IDENT of the RCU/TTR to be tested when requesting the test from the RTR-T.
- The RTR-T issues a MAP27 “Send Status Message 1” command (Status Message 1 signifying a Control Channel Test) to the MAP27 Gateway Node to reach the remote RCU/TTR with the specified IDENT.
- When the remote RCU detects Status Message 1 (indicating a Control Channel Test), the RCU causes the TTR to reply with Status Message 1.
- T&D specifies the number of retries to be performed by the RTR-T should the remote RCU/TTR not acknowledge with Status Message 1.
- The RTR-T responds to T&D with the result of the test (Passed/Failed) and the number of retries performed.

### **6.2 TRAFFIC CHANNEL TEST**

- The RCU receives a MAP27 Incoming Voice Call Message from the TTR.
- The RCU answers the call within the specified period of time of receiving the Incoming Voice Call MAP27 message by issuing a MAP27 Off-Hook command to the TTR.
- The RCU waits for the MAP27 Go-To-Channel message to be received from the TTR to indicate that an audio path to the RTR-T has been established.
- If the RCU does not receive the MAP27 ‘Go-To-Channel’ message within the specified period of time of issuing the Off-Hook message, the RCU terminates the call.
- Once the RCU receives the MAP27 Go-To-Channel message, the RCU waits for the test tones to be received within the specified period of time after which the RCU terminates the call.
- Once the RCU detects the test tones, it ensures that the received tones are the DTMF Test Tone digits A and D. These tones have been chosen because they are not easily replicated by Customer Terminal Equipment.
- The call will be terminated within the specified period of time if the received test tones are not the correct DTMF Test Tone digits.
- The RCU acknowledges & responds within the specified period of time by echoing the same DTMF Test Tone digits it received and verified.
- The RCU waits for the MAP27 Cleared message for a specified period of time of the acknowledgement tones being sent, after which time the RCU instructs the TTR to clear the call.

---

### **6.3 MODE CHANGE**

- The RCU, with the TTR radio transceiver operating in Trunked Mode, accepts a Mode Change Message (Status Message 10) sent from the RTR-T (over the control channel) to swap to PMR Mode.
- The RCU receives a Timer message specifying the time to remain in PMR mode (Status Message 11 – 18) sent from the RTR-T.
- The RCU acknowledges these messages (with Status Message 10) to the RTR-T and switches the mode of the Transceiver to PMR mode within a specified period of time of acknowledging the message.
- The RCU remains in the PMR mode of operation for the period of time specified in the Timer Message (Status Message 11 – 18) sent from the RTR-T.
- The RCU switches the Radio Transceiver back to the Trunked mode of operation once the period of time in the Mode Change message has elapsed or automatically if a Master Timer expires.



## 7. RCU-5056 - SRM9000 TTR INTERFACE SPECIFICATION

The complete RCU-5056 – SRM9000 TTR Interface specification is detailed in Design 2000 Document Number T/06168. It defines the both the serial data command and physical interface of the RCU.

### 7.1 T&D - RTR-T/P - TTR/RCU SEQUENCE DIAGRAMS

#### 7.1.1 Control Channel Test (CCT)

The sequence of messages from T&D through to the RCU for the Trunk Control Channel Test is shown in figure 8.

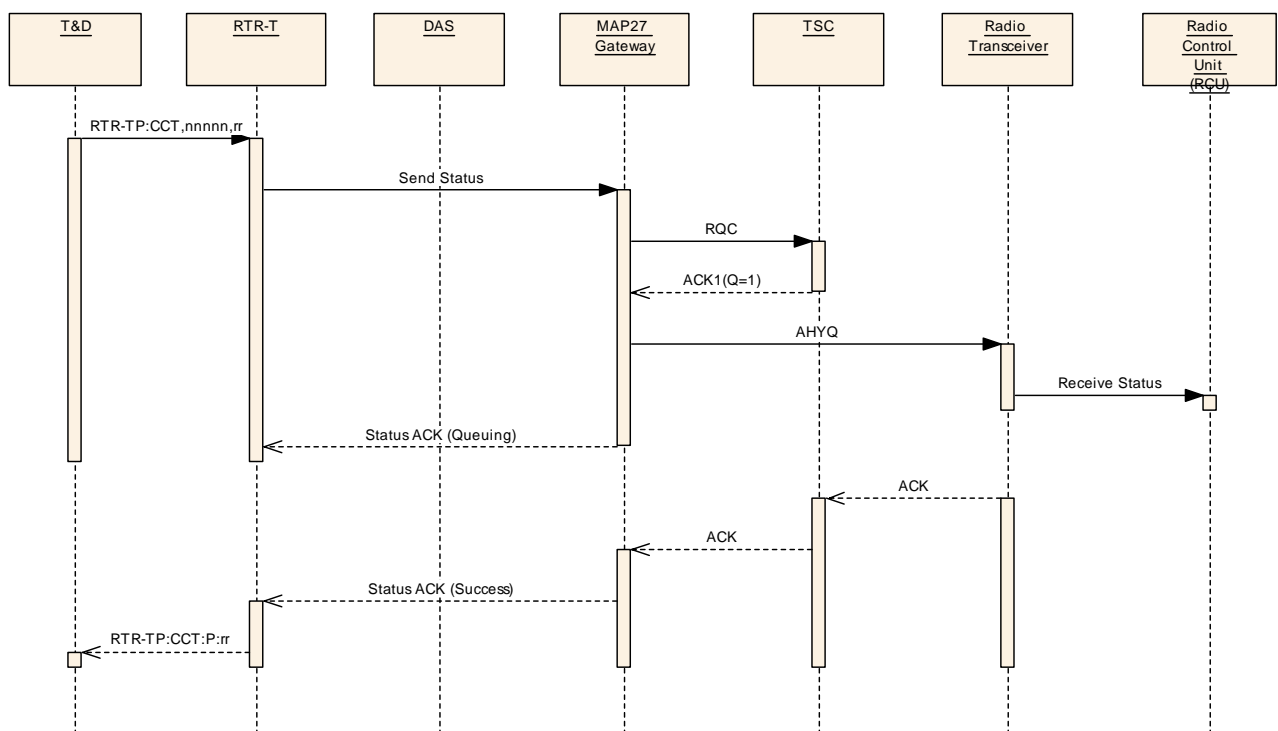

Figure 8: Control Channel Test Sequence Diagram

Here, T&D issues the CCT command specifying the IDENT of the Transceiver to be tested and the number of retries. The RTR-T/P translates this to a Status message which is sent to the Transceiver. After the RTR-T/P issues the Status message, it waits for the MAP27 gateway to issue a StatusACK (Success) and Status message reply which indicates that the TTR/RCU received and responded to the Status message. The RTR-T/P then responds to T&D with CCT with a Pass (P) clause.

**Note:** The Status Message for CCT is Status Message 1.

### 7.1.2 Traffic Channel Test (TCT)

The sequence of messages from T&D through to the RCU for the Trunk Control Channel Test is shown in Figure 9.

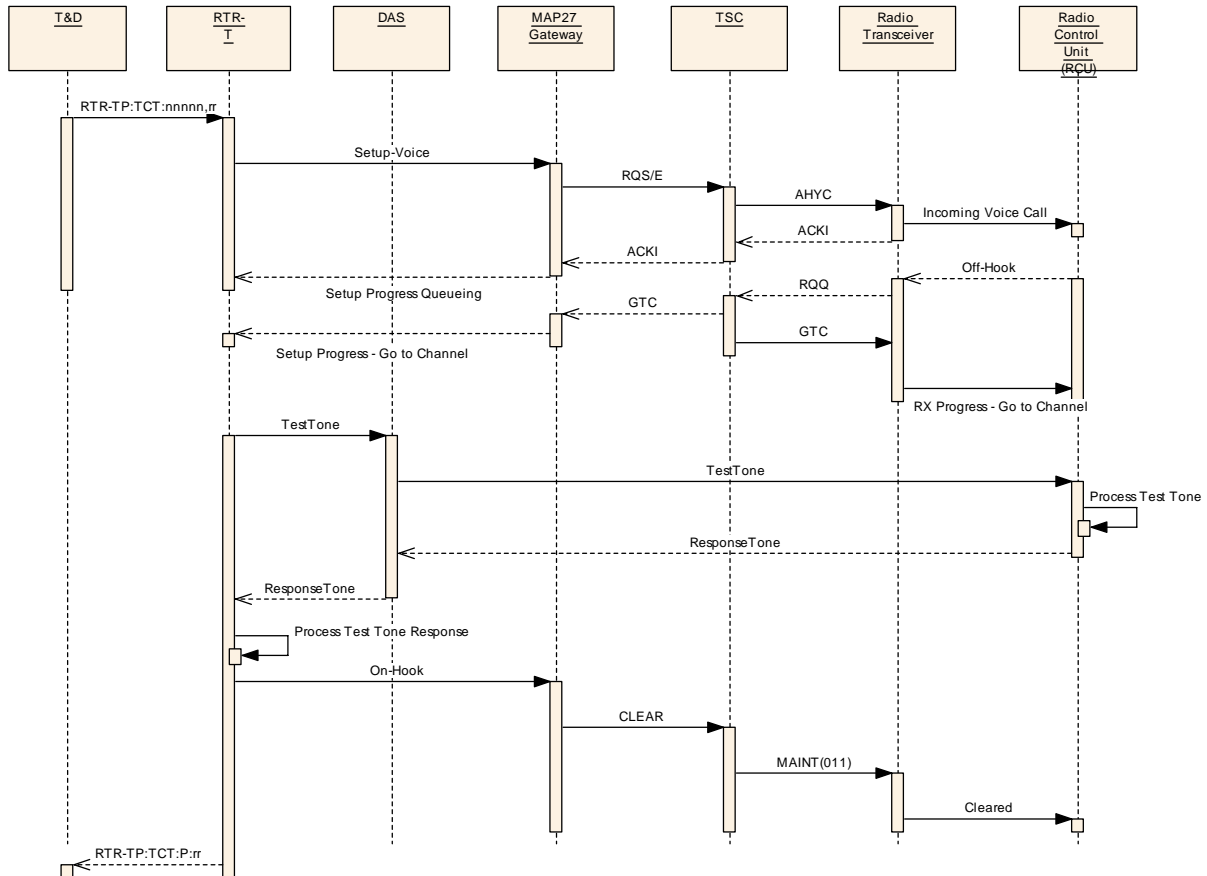

Figure 9: Traffic Channel Test Sequence Diagram

Here, T&D issues the TCT command specifying the IDENT of the Transceiver to be tested and the number of retries. The RTR-T/P translates this to a “Setup Voice” message which is sent to the Transceiver. After the RTR-T/P issues the “Setup Voice” message it waits for the MAP27 gateway to issue a “Go-To-Channel” message which indicates that the RCU has answered the Voice Call. On receipt of the “Go-To-Channel” message, the RTR-T/P issues two DTMF Test Digits each for 1500 ms. The RTR-T/P then waits for the RCU to respond with exactly the same DTMF Test Digits that it received and verified. If the correct DTMF digits are received and verified by the RTR-T/P, the Trunk Call is cleared down and the TCT response messages is sent to T&D with a response clause of Pass (P)

### 7.1.3 Mode Change

The sequence of messages from T&D through to the RCU for changing the mode of the Transceiver from Trunk to PMR mode is shown in Figure 10.

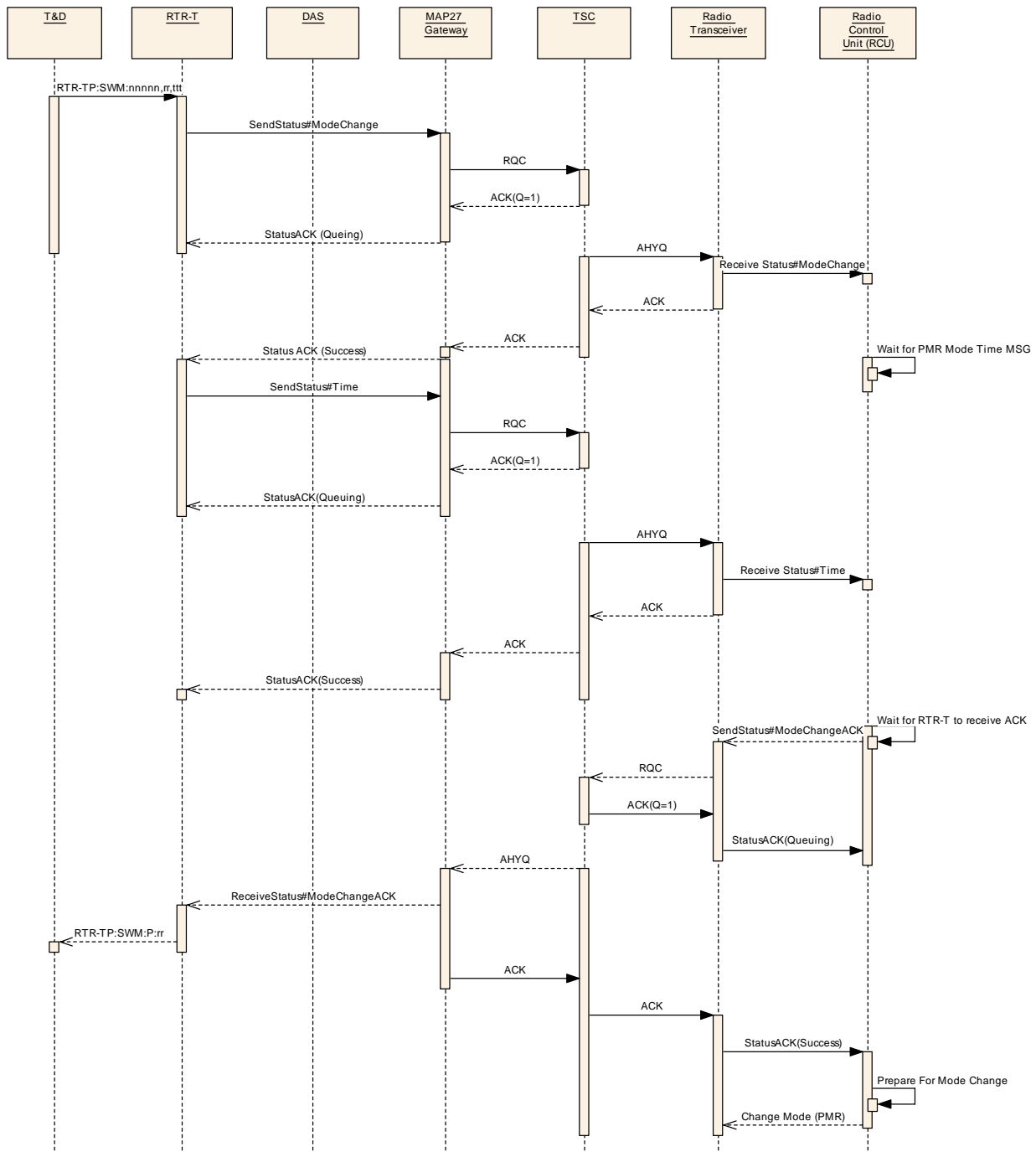

Figure 10: Transceiver Mode Change Sequence Diagram

Here, T&D issues the SWM command specifying the IDENT of the Transceiver to be Mode Switched, the number of retries and a final parameter which specifies the time that the Transceiver will remain in the PMR Mode.

The RTR-T/P translates the SWM to a Status message, sends it to the Transceiver and waits for the MAP27 gateway to issue a StatusACK (Success). When the Status message is received, the RCU replies with the same Status message and waits for the next Status message from the RTR-T/P that provides the timing information (Timer value T1 ... T8). When this is received, the RCU replies with the same Status message and RTR-T/P has full confirmation that the Mode Change message and the time period for which the Transceiver is to remain in PMR Mode have been received by the RCU. The RCU prepares for Mode Change and issues a command to the Transceiver to change to PMR mode.

**Note:** The Status Message for SWM is Status Message 10  
 The Status Messages for T1 → T8 are Status Messages 11 → 18.  
 Timer values are in 30 second increments starting at T1 = 30 seconds to T8 = 240 seconds.

### 7.1.4 Selcall Test (SCT)

The sequence of messages from T&D through to the RCU for the Selcall Test is shown in Figure 11.

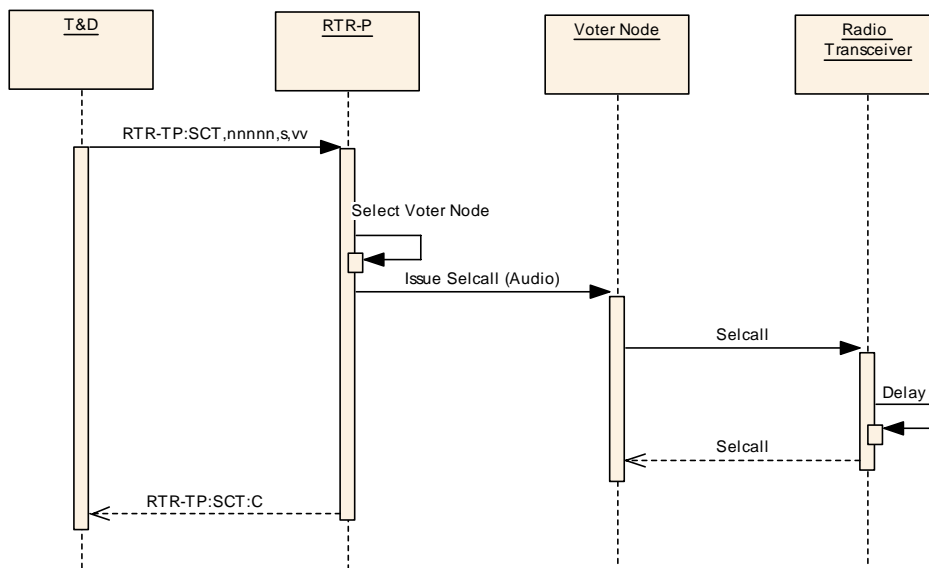

Figure 11: Selcall Test Sequence Diagram

Here, T&D issues the SCT command specifying the IDENT of the Transceiver to be tested and the Voter Node to be selected by the RTR-T/P when issuing the Selcall. Once the RTR-T/P selects the appropriate Voter Node, the RTR-T/P issues the Selcall over the Voter Node Audio interface. The RTR-T/P then issues a STC response with a clause of Complete [C] back to T&D.

## 8. RCU-5056 FIRMWARE

The RCU-5056 Firmware Source Code Reference Number is SW-5058  
 The RTR-T/P RT-5060 Firmware Source Code Reference Number is SW-5062

---

## 9. SPECIFICATIONS

Enclosure Dimensions	25 (high) x 196 (wide) x 160 (deep) (mm).
Finish	Dulux black onyx pearl powder coat.
Power Requirement	12 Vdc nominal (10.8→16Vdc), polarity sensitive.
Power Consumption	75 mA max. @ 12V 0.9 W
Operating Temperature Range	-10 → +60 °C.
Storage Temperature Range	-20 → 80 ° C ambient.
Humidity, Storage and Operating	To 98% non-condensing.
Mean Time Between Failure:	> 20 years.
Processor	PIC18F4550
Processor Speed	20 MHz XTAL, internally multiplied to 48MHz
On Board RAM	2KB
On Board FLASH	32KB
On Board EEPROM	256B
In-band Signaling	<u>D</u> ual <u>T</u> one <u>M</u> ulti <u>F</u> requency (DTMF) & 5 Tone Sellcall.
DTMF Dialer	1500 ms on / 260 ms off, -6dBm.
DTMF Receiver	-26 → 0 dBm sensitivity.
5 Tone Paging Protocol	CCIR 40 ms, -14dBm.
Status Messages	1: Control Channel Test 10: Swap to PMR mode 11 – 18: Timer Values T1 – T8.
Displays	5 x status LEDs.
Controls	Reset, Update
Radio Control Port	19,200 baud, 8N1 format, TTL levels (0-5V).
Tx Audio Impedance	>1K Ohms
Rx Audio Impedance	600 Ohms
Diagnostic RS232 Port	115,200, 8N1 format, RS-232 levels (± 12V).
Universal Serial Bus	USB 2.0 Type B
ACMA Supplier's Code Number	N468.
Warranty	Two years

*Note: Specifications are subject to change without notice.*

N468



---

# **RADIO CONTROL UNIT**

RCU-5056

DUAL MODE TRUNKED/PMR  
RADIO CONTROL INTERFACE  
FOR  
SIMOCO SRM9000

MADE IN AUSTRALIA BY

**design2000**  
Est.1968 [www.design2000.com.au](http://www.design2000.com.au)

FOR

**FUJITSU**  
OSS Technologies

---

# **RCU-5056**

## **PACKING LIST**

1 x RCU UNIT Model RCU-5056

1 x G/06165 OPERATOR MANUAL

1 x RJ45 → R45 LINE CORD (90mm)

1 x DB15 MALE ↔ DB15 FEMALE CABLE (90mm)

4 X M4 by 10mm SCREWS (PHILIPS HEAD)

4 X 7 GAUGE 16mm SELF-TAPPERS (PHILIPS HEAD) – TO ORDER

---

# **RCU-5056**

## **SELF TEST MODE**

It is possible to enter the RCU into a Self-Test mode to exercise the internal circuitry and operating LEDs.

The RCU is placed into test mode by applying power to the unit, then holding the "Update" button for three seconds. The unit will then indicate that it is in test mode by cycling the status LEDs on the front panel from left to right.

While the test mode is active the unit's processor constantly stress-tests itself and all auxiliary components including the RS-232 line driver chip, DTMF transceiver chip and operational amplifier.

The unit's Microchip 18F4550 microcontroller is made to exercise all of its instruction set commands and five I/O ports. All on-chip timers are started and trigger regular processor interrupt routines which reset the timers to perform another cycle.

The test mode should be cancelled by removing power from the unit, rather than by pressing the "Reset" button, to ensure no components are left in an unstable state by the exhaustive test process.



**DESIGN TWO THOUSAND PTY LTD**

**03 9758 5933**